

Vibrational Energy Harvester Using Electric Double Layer Electret

Shimpei Ono* and Kazumoto Miwa

Central Research Institute of Electric Power Industry, 2-6-1 Nagasaka, Yokosuka, Kanagawa 240-0196, Japan

(Received March 31, 2022; accepted April 20, 2022)

Keywords: energy harvester, electric double layer electrets, ionic liquids

We have demonstrated a new type of vibrational energy harvester based on an electret called an electric double layer electret (EDLE) and its application as a vibrational energy harvester. By mechanically modulating the interfacial area between the vibrating electrode and the EDLE, the electrode is electrostatically charged and discharged at different phases and an electric current is generated. Owing to the extremely high density of carriers that accumulate at the EDLE interface, vibrational energy harvesters have the unique capability to electrostatically leverage high-density charge accumulation at the electrode. The power obtained in this study was as high as 10 nJ/cm^2 with a resistance of $1 \text{ M}\Omega$ even with a vibration frequency as low as 1 Hz .

1. Introduction

The natural world is full of minute energy sources such as light, heat, vibration, and radio waves. In recent decades, energy harvesters have been extensively investigated as a means of harvesting these minute energies as an alternative energy source to batteries. Owing to the low power consumption of semiconductor devices, electric circuits can be driven by even these small energies. Among the energy harvesters, particular attention has been devoted to electrostatic energy harvesters since they are suitable for obtaining current from low-frequency and low-amplitude vibration sources, and can be easily integrated into microsystems.^(1–7) However, enhancing the output power to enable the operation of autonomous sensors and wearable devices has been regarded as a serious technological challenge.

In this work, we introduce a new type of electret called an electric double layer electret (EDLE) and apply it as a vibrational energy harvester (VEH). It is well known that when a voltage is applied to an electrolyte, electric double layers (EDLs) are formed at the interface between the electrode and electrolyte after ionic redistribution as shown in Fig. 1(a). The distance between the ions and the electrode is less than 1 nm ; thus, a strong electric field is concentrated. In recent years, the EDL of ionic liquids (ILs) has attracted attention as a means of injecting high-density charge into materials owing to its ability to create electronic devices that can be driven at extremely low voltages, surpassing conventional semiconductor technology centered on silicon.^(8–11) The EDLE is formed by anchoring the motion of ions inside an ion gel after the

*Corresponding author: e-mail: shimpei@criepi.denken.or.jp
<https://doi.org/10.18494/SAM3910>

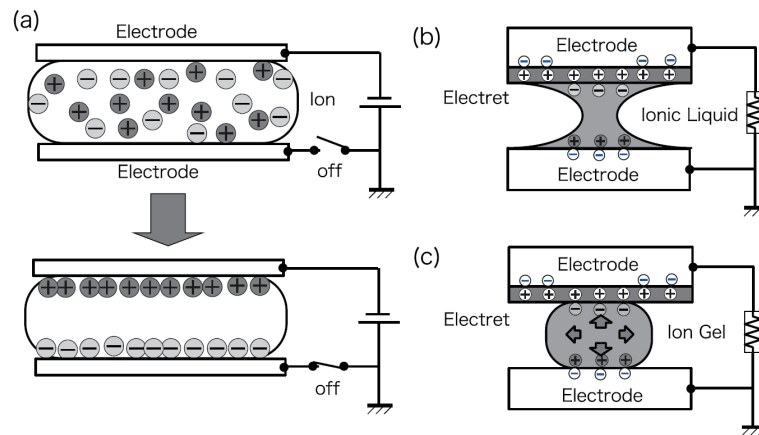

Fig. 1. (a) Schematic of EDL. When voltage is applied to the electrolyte, an EDL is formed. (b) VEH using an EDLE. With an IL alone, the IL spreads over the entire surface of the electrodes. (c) VEH using an ion gel. The contact area can be varied by using the ion gel.

formation of an EDL and can sustain the EDL without any external bias-voltage source. The advantage of using an EDLE is that it sustains a large number of carriers at the surface, and a large current can be electrostatically obtained by using an EDLE as a VEH.

2. Materials and Methods

The VEH introduced here uses the electrostatic induction method. Electrostatic induction means that when an electret approaches an electrode, a charge opposite to that of the electret is induced in the electrode. By connecting a load resistor to the electrode and grounding the other side, an electric current is generated according to the movement of the electrode. In this way, kinetic energy can be converted into electrical energy. The space between the electret and the counter electrode in the standard VEH is air or a vacuum. To enhance the density of the electric flux line between the electrode and electret, new types of energy harvesters using microfluidics have been proposed.^(12–14) The electrolytes are inserted between the electret and the counter electrode in this technique. Owing to the charge of the electret or the external bias-voltage source, an EDL is formed at the interfaces between the electret and the electrolyte and between the electrode and the electrolyte. The EDL can be regarded as two serially connected capacitors. The electrodes are electrostatically charged and discharged at different phases by mechanically modulating the interfacial area between the vibrating electrode and the EDL.

Among all electrolytes, ILs, known as room-temperature molten salts, are suitable for this application since the capacitance of ILs is known to be as high as $170 \mu\text{F}/\text{cm}^2$. In fact, by using ILs as the electrolyte for a VEH, the electric current generated becomes as high as $2 \mu\text{A}/\text{cm}^2$ with a load resistance of $1 \text{ k}\Omega$.⁽¹⁵⁾ However, a problem is that the ILs are gradually spread over the entire surface of the electret and the electrode, resulting in almost no change in the area between the IL and the electrode as shown in Fig. 1(b). To avoid this situation, we use an ion gel consisting of an IL and a polymer matrix to maintain the shape of the electrolyte as shown in

Fig. 1(c). The IL gel prevents the IL from spreading and maintains a large displacement of the contact area. Indeed, for a VEH with IL gel, the generated current becomes 10 times higher than that of the IL alone, and a current of about $22 \mu\text{A}/\text{cm}^2$ with a load resistance of $1 \text{ k}\Omega$ is obtained.⁽¹⁶⁾ However, an external bias-voltage source⁽¹⁶⁾ or the use of dielectric materials on the surface of the electrode⁽¹⁷⁾ is necessary to sustain the EDL.

To overcome these problems, we convert the EDL of the ILs itself into an EDLE and apply it to the VEH. The EDLE is formed by anchoring the motion of ions inside the IL gel after the formation of the EDL, and it can sustain the EDL without any external bias-voltage source.⁽¹⁸⁾ The EDL electrets are formed with acrylate polymer and the IL [(2-methacryloyloxyethyl) trimethylammonium bis(trifluoromethanesulfonyl) imide], both of which have unsaturated bonds in the molecular structure. By using ILs with unsaturated bonds, ions can be immobilized semi-permanently by chemically bonding them to polymer networks by polymerization to make the EDLE.

We first dissolve the acrylate polymers with acetonitrile and then add the IL and a polymerization initiator. This mixture is sandwiched with two electrodes (one is Au and the other is indium tin oxide deposited on top of glass), where a bias voltage of 3 V is applied to form the EDL. This bias voltage is limited by the chemically stable windows of the ILs and depends on the combination of cations and anions. We measure the current between the two electrodes after applying the bias voltage and wait until the current starts to saturate. At this stage, both cations and anions are redistributed to form the EDL at the interface between the electrode and the mixture of the IL and polymer. After this process, we expose the EDL to UV light (235 nm) to accelerate polymerization from the ITO electrode side, as shown in Fig. 2(a). The current between the two electrodes starts to decrease with exposure to UV light and becomes less than 1 nA. This is because the reduction in the number of mobile ions increases the resistance of the mixture of polymer and ILs. We applied the voltage before and after the polymerization and compared the current that flows between two contacts, and we predicted that 99% of the ions are fixed to the polymer networks.

Once we solidify ILs inside the polymer, we can sustain the EDL without applying a voltage. During the polymerization process, we use spacers to define the height and obtain the flat surface of the EDLE. The typical size of the EDLE is 5 mm diameter and 100 μm height as shown in Fig. 2(b). All the processes are carried out in a glove box to prevent the effects of

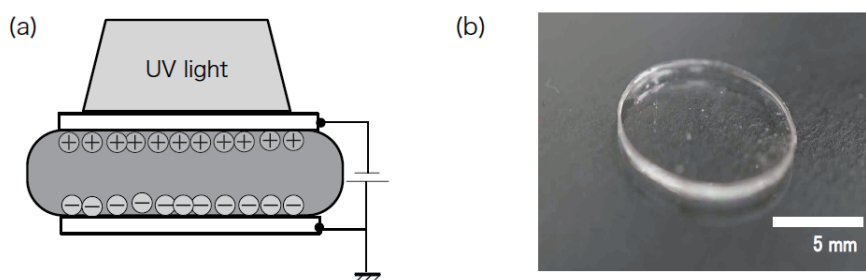

Fig. 2. (a) Fabrication of EDLE polymerized by UV irradiation. (b) Photograph of EDLE.

moisture and oxygen in the air. One of the most significant advantages of the EDLE is that all the processes are carried out at room temperature with the application of a low voltage, whereas a conventional electret requires high-temperature charging processes.^(19,20)

3. Results

Figure 3 shows a conceptual diagram of our contact/release-type VEH using an EDLE. The EDLE is placed between two parallel electrodes made of a thin layer of Au deposited on top of glass. The distance between the electrodes is mechanically modulated by vertically vibrating the top electrode. By physically placing the EDLE in contact with the electrode and then breaking the contact, charge is accumulated or released from the electrode by electrostatic induction. Since the considerable capacitance of the EDL can be utilized, it is expected that a large current can be obtained.

Figure 4 shows the output voltage at both ends of a load resistance of 1 M Ω obtained by a VEH with the cation side [Fig. 4(a) and anion side Fig. 4(b)] of the EDLE. The EDLE is sandwiched between electrodes and repeatedly placed in contact with the electrodes and dissociated from the electrodes by vibrating it at 1 Hz using a square wave driven by a shaker. The performance of the VEH is measured inside a glove box filled with nitrogen to prevent the effects of water and oxygen, which cancel the surface charge of the EDLE. It was found that each time the electrode comes in contact with and dissociates from the EDLE, an output voltage is obtained and the direction of the generated voltage is reversed. As a result, the output voltage reaches a maximum of 4 V and the integrated current of one peak of about 10 nJ/cm² is obtained. This is the highest ever current density reported for a VEH using an EDL and is due to the large capacitance of the EDL.

Note that the voltage starts to decrease and show a negative sign and then become positive just before and after the EDLE comes in contact with the electrode, respectively, as shown in the inset of Fig 4(a). This is because the electric charge is induced by electrostatic induction as the EDLE approaches the electrode. To verify the effects of the cation and anion sides on the EDLE, we reverse the orientation of the EDLE. We find that the sign of the output voltage is reversed when the EDLE is dissociated from the electrode. This suggests that the EDL is indeed sustained by polymerization without any bias voltage.

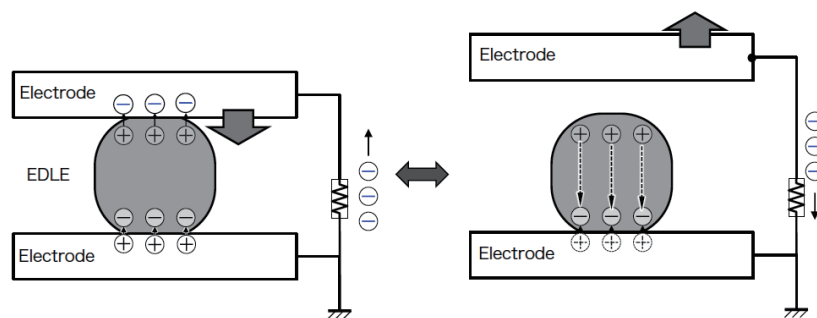

Fig. 3. Mechanism of VEH with EDLE. A large current is generated when the electrode comes into contact through electrostatic induction.

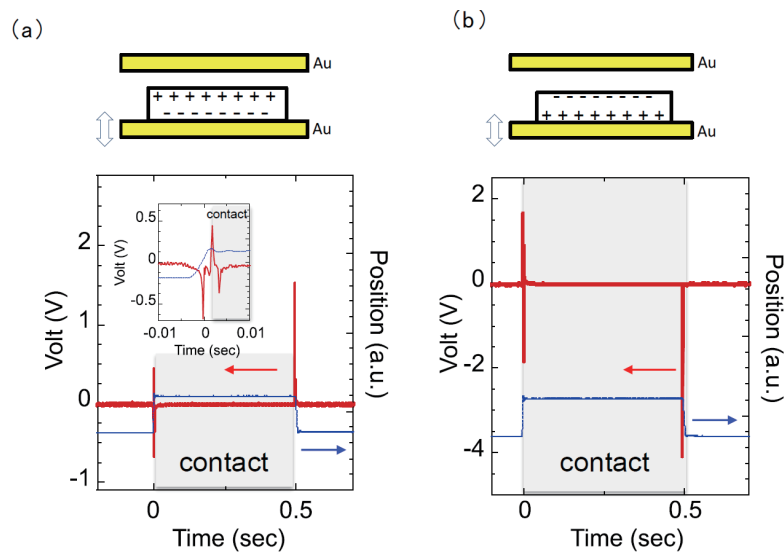

Fig. 4. (Color online) Output voltage at both ends of load resistance of $1\text{ M}\Omega$ of VEH with (a) cation side of EDLE and (b) anion side of EDLE. The inset shows the enlarged voltage of VEH with cation side of EDLE.

4. Discussion

Here, we consider what is needed to drive a wireless sensor terminal with the VEH using the ELDE. The VEH generates electricity each time the electrodes come in with and dissociate from the EDLE. Thus, if the vibration amplitude is sufficiently large, the VEH can convert electricity from low to high frequencies. Also, the amount of electricity generated will increase with increasing surface area in contact with the electrode. To increase the surface area in contact with the electrode, microfabrication techniques have been used to create bumps on the surface of the EDLE to increase the amount of electricity generated.⁽²¹⁾ The structure of the VEH is another factor determining the power, and we have modified the design of the VEH using the EDLE.⁽²²⁾ Just as magnets are an essential material for the modern electronics industry, we believe that the EDLE will reveal a high potential that humanity has yet to see. This research has just begun, and we can expect significant progress in the future.

5. Conclusions

In this paper, we presented a novel material called an EDLE and its application as a VEH. We have succeeded in sustaining the EDL of an electrolyte without any bias voltage to form an EDLE. The output voltage is generated in the circuit by placing the EDL electret in contact with the electrodes and releasing the contact. Owing to the high density of carriers accumulated at the interface of the EDLE, VEHs have the unique capability to leverage high-density charge accumulation to electrodes electrostatically. The power obtained in this study was as high as $16\ \mu\text{W}/\text{cm}^2$ with a resistance of $1\text{ M}\Omega$ even with a vibration frequency as low as 1 Hz.

Acknowledgments

This work was supported by JST PRESTO Grant Number JPMJPR17R3; JST CREST Grant Numbers JPMJCR15Q4 and JPMJCR21Q2, Japan; and JSPS KAKENHI Grant Number 20H05304.

References

- 1 S. Roundy, P. K. Wright, and J. Rabaey: *Comput. Commun.* **26** (2003) 1131. [https://doi.org/10.1016/S0140-3664\(02\)00248-7](https://doi.org/10.1016/S0140-3664(02)00248-7)
- 2 S. P. Beeby, M. J. Tudor, and N. M. White: *Meas. Sci. Technol.* **17** (2006) 175. <https://doi.org/10.1088/0957-0233/17/12/R01>
- 3 Y. Suzuki: *IEEJ Trans. Electr. Electron. Eng.* **6** (2011) 101. <https://doi.org/10.1002/tee.20631>
- 4 H. Toshiyoshi, S. Ju, H. Honma, C.-H. Ji, and H. Fujita: *Sci. Technol. Adv. Mater.* **20** (2019) 124. <https://doi.org/10.1080/14686996.2019.1569828>
- 5 N. A. Hoque, P. Thakur, S. Roy, A. Kool, B. Bagchi, P. Biswas, M. M. Saikh, F. Khatun, S. Das, and P. P. Ray: *ACS Appl. Mater. Interfaces* **9** (2017) 23048. <https://doi.org/10.1021/acsomega.9b00243>
- 6 M. K. Gupta, S.-W. Kim, and B. Kumar: *ACS Appl. Mater. Interfaces* **8** (2016) 1766. <https://doi.org/10.1063/1.4976803>
- 7 X. Chen, X. Li, J. Shao, N. An, H. Tian, C. Wang, T. Han, L. Wang, and B. Lu: *Small* **13** (2017) 1604245. <https://doi.org/10.1002/smll.201604245>
- 8 H. Shimotani, H. Asanuma, A. Tsukazaki, A. Ohtomo, M. Kawasaki, and Y. Iwasa: *Appl. Phys. Lett.* **91** (2007) 082106. <https://doi.org/10.1063/1.2772781>
- 9 M. Nakano, K. Shibuya, D. Okuyama, T. Hatano, S. Ono, M. Kawasaki, Y. Iwasa, and Y. Tokura: *Nature* **487** (2012) 459. <https://doi.org/10.1038/nature11296>
- 10 K. Shimamura, D. Chiba, S. Ono, S. Fukami, N. Ishiwata, M. Kawaguchi, K. Kobayashi, and T. Ono: *Appl. Phys. Lett.* **100** (2012) 122402. <https://doi.org/10.1063/1.3695160>
- 11 J. Lieb, V. Demontis, D. Prete, D. Ercolani, V. Zannier, L. Sorba, S. Ono, F. Beltram, B. Sacepe, and F. Rossella: *Adv. Funct. Mater.* **29** (2019) 1804378. <https://doi.org/10.1002/adfm.201804378>
- 12 T. Krupenkin and J. A. Taylor: *Nature Commun.* **2** (2011) 448. <https://doi.org/10.1038/ncomms1454>
- 13 J. K. Moon, J. Jeong, D. Lee, H. K. Pakand, and J. A. Taylor: *Nature Commun.* **4** (2013) 1487.
- 14 S.-H. Kwon, J. Park, W. K. Kim, Y. J. Yang, E. Lee, C. J. Han, S. Y. Park, J. Lee, and Y. S. Kim: *Energy Environ. Sci.* **7** (2014) 3279. <https://doi.org/10.1039/C4EE00588K>
- 14 S. Yamada, H. Mitsuya, and H. Fujita: *IEEE Proc. PowerMEMS* **2014** (2014) 55.
- 15 S. Yamada, H. Mitsuya, and H. Fujita: *IEEE Proc. MEMS* (2015) 118.
- 16 L. E. Helseth and X. D. Guo: *Langmuir* **31** (2015) 3269. <https://doi.org/10.1021/la503494c>
- 17 C. Sano, H. Mitsuya, S. Ono, K. Miwa, H. Toshiyoshi, and H. Fujita: *Sci. Technol. Adv. Mater.* **19** (2018) 317. <https://doi.org/10.1080/14686996.2018.1448200>
- 18 S. Ono, K. Miwa, J. Iori, C. Sano, H. Toshiyoshi, H. Fujita, H. Mitsuya, and K. Ishibashi: *Symp. Design, Test, Integration and Packaging of MEMS/MOEMS (DTIP, 2017)* 7984482. <https://doi.org/10.1109/DTIP.2017.7984482>
- 19 Y. Suzuki: *IEEJ Trans. Elec. Electron. Eng.* **6** (2011) 101. <https://doi.org/10.1002/tee.20631>
- 20 Toshiyoshi, S. Ju, H. Honma, C.-H. Ji, and H. Fujita: *Sci. Technol. Adv. Mater.* **20** (2019) 124. <https://doi.org/10.1080/14686996.2019.1569828>
- 21 T. Iida, T. Tsukamoto, K. Miwa, S. Ono, and T. Suzuki: *Sens. Mater.* **31** (2019) 2527. <https://doi.org/10.18494/SAM.2019.2309>
- 22 K. Tamura, K. Nota, K. Miwa, S. Ono, and D. Yamane: *Power MEMS* **2021** (2021) 100. <https://doi.org/10.1109/PowerMEMS54003.2021.9658364>